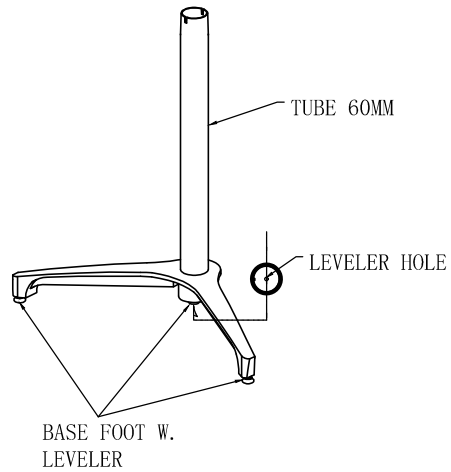
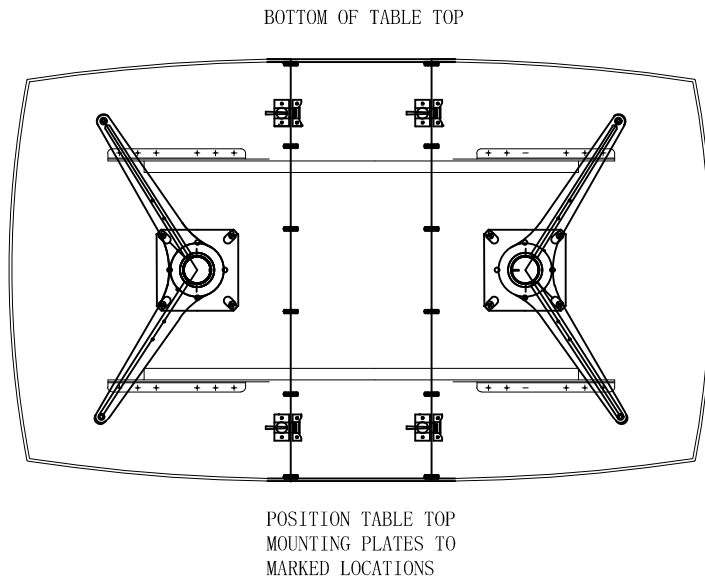
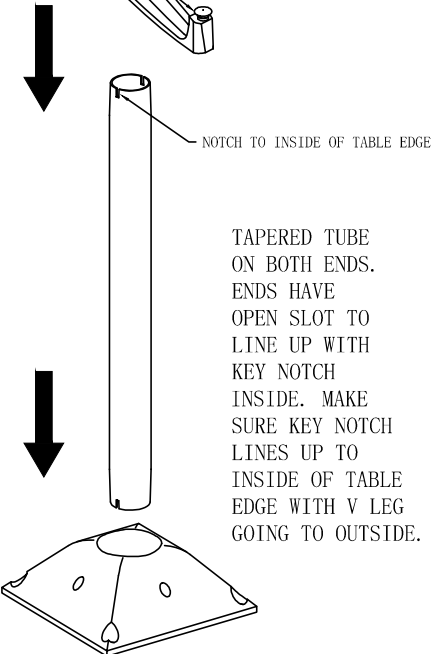
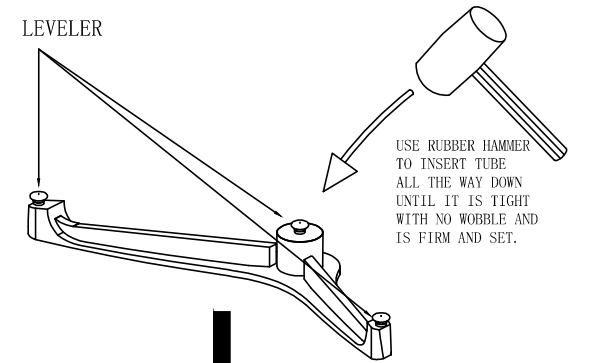

TABLE ASSEMBLY VB01



PACK ENCLOSED:

- A) TAPERED NOTCHED TUBE ON BOTH ENDS (2)
- B) V LEG WITH LEVELERS (2) WITH (6) LEVELERS TOTAL.



ASSEMBLY ORDER:

- 1) HAMMER 2 TAPERED TUBES INTO MOUNTING PLATES UNTIL IT IS FIRM AND DOES NOT WOBBLE. MAKE SURE NOTCH AND KEY LINE UP.
- 2) TAP V LEG BOTTOM ENDS WITH LEVELERS WITH HAMMER UNTIL FIRM LIKE TUBE PLACEMENT.
- 3) TOTAL HEIGHT OF BASE IS 28.75". THEN FLIP TABLE OVER. TOTAL HEIGHT OF TABLE SHOULD BE APPROXIMATELY 29.5" BEFORE LEVELING TO FLOOR.